

Simplorer 9.0

Simplorer® is a multi-domain simulation software program that enables engineers to model, simulate, analyze and optimize complex systems including electromechanical, electromagnetic, power and other mechatronic designs. Using Simplorer's powerful modeling features and communication backplane technology, engineers are able to construct virtual prototypes of all aspects of a system including the electronics, sensors/ actuators, motors, generators, power converters, controls and embedded software. This enables engineers to investigate system functionality and performance and to verify overall design. The result is a dramatic reduction in development time and cost, increased system reliability and performance optimization.

Facilitates System Design – Simplorer offers multiple modeling techniques including circuits, block diagrams, state machines, equation level, and modeling languages such as VHDL-AMS, SML (Simplorer Modeling Language), and C/C++. These can be used concurrently allowing engineers to easily model analog, digital, and mixed signal multi-domain designs. This flexibility eliminates the need for error-prone mathematical transformations and model analogies often employed by single-domain simulation tools.

Physics-Based Modeling – For system component models requiring the highest level of accuracy, Simplorer provides a direct link to ANSYS' industry-leading electromagnetic field simulation software: Maxwell®, Q3D Extractor®, RMxprt™, PExprt™, HFSS™, Slwave™ as well as ANSYS® Icepak®, ANSYS Rigid Dynamics and ANSYS® Mechanical™ products. The coupling technology and the model reduction techniques provide the capability to incorporate detailed physics based models within Simplorer.

Integrated Development Environment – Simplorer provides a powerful environment to develop virtual prototypes that can be shared among hardware and software design groups allowing users to emulate hardware and simulate the software.

Statistical Analysis and Optimization – Simplorer includes parametric, optimization, sensitivity, statistical, and tuning analysis capabilities. These advanced analysis capabilities allow users to optimize the design based on a set of performance measurement criteria and provide insight into design variations and "trade-offs." Statistical analysis has fully integrated the SAE VHDL-AMS Statistical Package.

Distributed Analysis – Simplorer can leverage available computing power with distributed analysis options for fast turnaround of your largest designs.

VHDL-AMS Modeling – Simplorer fully supports the IEEE standard (1076.1) VHDL-AMS modeling language for mixed signal and multi-domain systems. It provides both continuous-time and event-driven modeling semantics, and is suitable for analog, digital, and mixed analog/digital circuits. VHDL-AMS also facilitates modeling of multi-domain systems that can include a combination

Industry Solutions

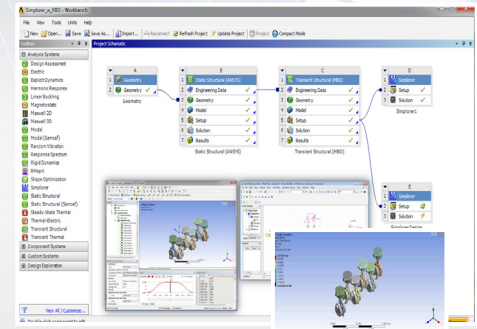

Simplorer 9.0 is now integrated with ANSYS Workbench

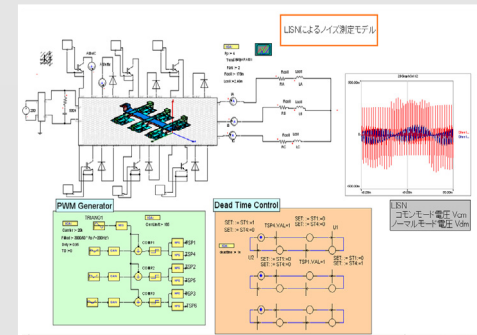

Simplorer can simulate complete systems including inverter, control algorithms and rigid body dynamics

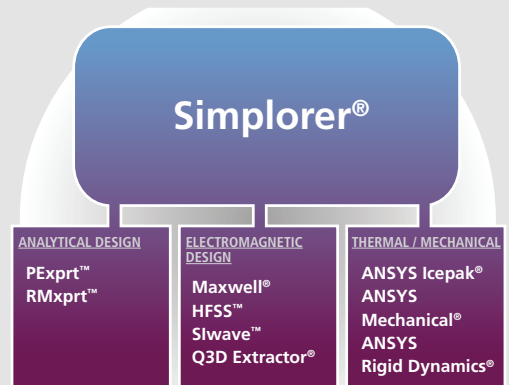

Product Features

Modeling Techniques

- VHDL-AMS – IEEE standard 1076.1 is a true modeling language that provides extensive capability and exchange able complex models for analog, mixed-signal and multi-domain designs
- Circuits – fast circuit simulation includes multilevel semiconductor modeling, and data exchange between models
- Block Diagrams – signal flow based models for linear, nonlinear, continuous, time-discrete hybrid-systems
- State Machines – event driven approach for complex modeling and logic control (i.e. space vector control, PWMs)
- Equation Blocks – quickly include equation based modeling in the system
- Spice Model Import – takes advantage of existing models
- Physical Based Model Import – incorporates high fidelity finite element and/or boundary element analysis level models

Co-Simulation and Model Generation

- Maxwell, Q3D Extractor, RMXprt, PEXprt, HFSS, Slwave, ANSYS Rigid Dynamics, ANSYS Mechanical
- Third Party products- MATLAB/Simulink, MathCAD, C/C++, ModelSim, QuestaSim, RTW

Statistical Analysis and Optimization

- Parameter sweep
- Statistical Analysis (Monte Carlo) including the SAE (Society of Automotive Engineers) VHDL-AMS Statistical Package
- Sensitivity
- Optimization
 - Sequential nonlinear programming
 - Sequential mixed integer nonlinear programming
 - Quasi Newton
 - Pattern search
 - Genetic algorithm
- Tune
- Post-processing
 - 2-D and 3-D families display
 - 2-D and 3-D polar families display views
 - Digital plots with families display
 - Rectangular stacked families display
 - Bode and Nyquist families display

of electrical, mechanical, thermal, hydraulics, and magnetic models. Models can be exchanged between different simulation tools that adhere to the VHDL-AMS standard ensuring compatibility between software tools and preserving legacy models.

Simulator Performance Technology – Simplorer's unique simulator coupling and co-simulation technologies utilize a data exchange backbone, which connect to optimum simulators with numerical algorithms specifically tuned for the multi domain nature of dynamic systems. These technologies allow users to create high fidelity models across multiple domains, at different levels of abstraction, and simulate the entire complex system.

Co-Simulation – C/C++ programs, MATLAB®/Simulink®, ModelSim®, QuestaSim®, Mathcad® and other specialized programs can be directly integrated into Simplorer. This allows users to utilize customized code and existing feedback/control legacy design. The direct integration of models in their native environment avoids model translation, saves design time and allows communication and model exchange across departments and between suppliers and OEMs.

Device Characterization Tools – Simplorer supports powerful device and system component characterization tools including IGBT Model generation and DC/DC Converter behavioral modeling. These tools, developed in collaboration with industry leading experts, allow users to easily characterize IGBT's and DC/DC converters creating behavioral, average, and dynamic models for use in Simplorer.

Scripting – This powerful feature opens APIs in the Simplorer environment, allowing Simplorer to be embedded into existing design flows. The scripting capability, including script recording, is language independent so users can work with popular scripting languages, such as Visual Basic®, Java® and interact easily with other tools supporting the Microsoft™ Com interface.

Manufacturer's Models – Simplorer users can access our model web site (<http://model.simplorer.com>) for up-to-date manufacturer-specific components such as Diodes, MOSFETs, IGBTs, Opamps, among others. This site also allows the user to search for specific models based on desired component characteristics.

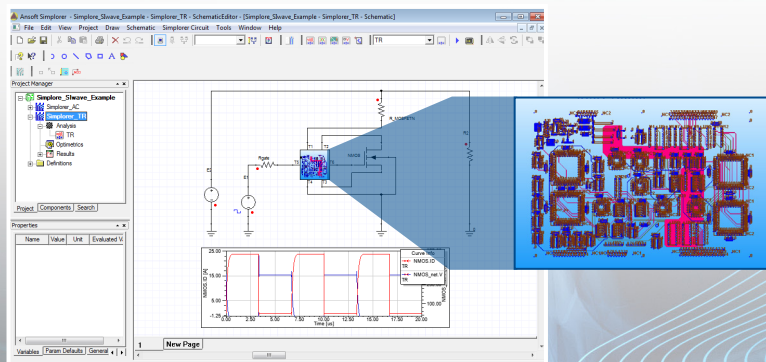

Simplorer 9.0 has new integration with Slwave for signal integrity applications

Product Features

Statistical Analysis and Optimization Continued

- Interactive data table view
- Histogram
- Sensitivity report
- Range function capabilities

Scripting

- Visual Basic
- Java

Device Characterization Tools

- IGBT
 - Average model
 - Dynamic model
- DC/DC Converters
 - VHDL-AMS behavioral model

Usability

- Scriptable user interface
- On-Schematic reports
- Multi-page model definition with page ports
- Model time stamp on either encrypted or encoded text models
- Tool bar and menu customization
- Including datasets into projects files
- Including documentation files into projects files

Applications

- Power electronics
- Electric motors and drives
- Automotive electronics
- Mechatronic systems
- Industrial automation
- Hybrid-electric and plug-in
- Hybrid propulsion

The ANSYS Advantage

With the unequalled depth and unparalleled breadth of ANSYS engineering simulation solutions, companies are transforming their leading edge design concepts into innovative products and processes that work. Today, almost all of the top 100 industrial companies on the "FORTUNE Global 500" invest in engineering simulation as a key strategy to win in a globally competitive environment. They choose ANSYS as their simulation partner, deploying the world's most comprehensive multiphysics solutions to solve their complex engineering challenges. The engineered scalability of solutions from ANSYS delivers the flexibility customers need, within an architecture that is adaptable to the processes and design systems of their choice. No wonder the world's most successful companies turn to ANSYS — with a track record of 40 years as the industry leader — for the best in engineering simulation.

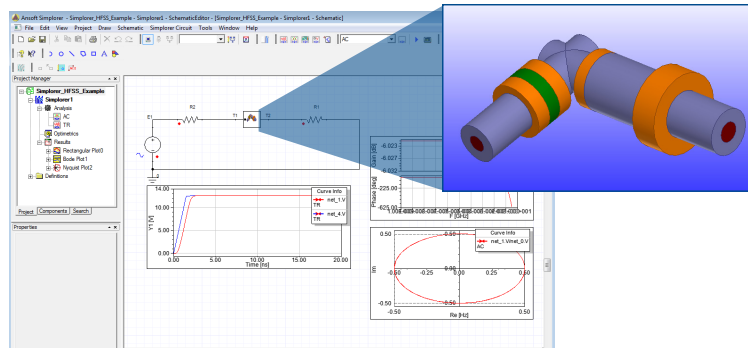

Simplorer's integration with HFSS allows users to simulate high-frequency systems

ANSYS[®]
www.ansys.com

ANSYS, Inc.
Southpointe
275 Technology Drive
Canonsburg, PA 15317
U.S.A.
724.746.3304
ansysinfo@ansys.com

Toll Free U.S.A./Canada:
1.866.267.9724
Toll Free Mexico:
001.866.267.9724
Europe:
44.870.010.4456
eu.sales@ansys.com



GSA Contract Holder

ANSYS, ANSYS Workbench, Ansoft, AUTODYN, CFX, FLUENT, and any and all ANSYS, Inc. brand, product, service and feature names, logos and slogans are registered trademarks or trademarks of ANSYS, Inc. or its subsidiaries in the United States or other countries. All other brand, product, service and feature names or trademarks are the property of their respective owners.

© 2010 ANSYS, Inc. All Rights Reserved. Printed in U.S.A. MKT0000522 10-10